

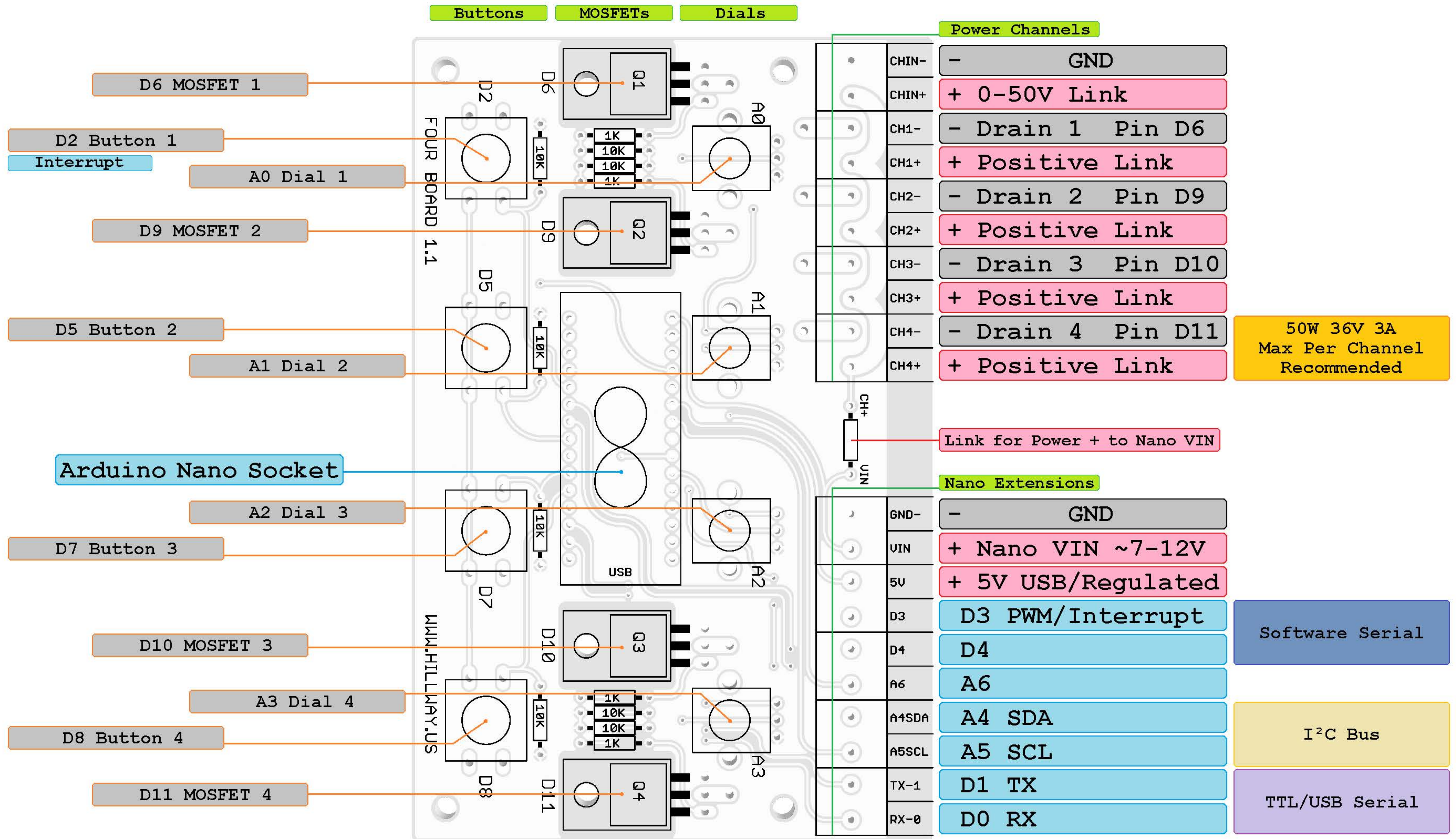

Four Board 1.1

Open-Source I/O Power Board for Arduino Nano



<http://www.hillway.us/fourboard>